



**AVERY
DENNISON**

Fastener
Solutions

Fine Fabric™ Fasteners Marketing Specifications

For the following part numbers:

08938-0

08939-0

10343-0

10347-1

10446-2

10670-0

10672-2

10689-0

10701-0

11092-0

11094-0

11096-0

11102-0

11103-0

11105-0

16022-0

16023-0

16024-0

16025-0

16026-0

06431 (Europe)

04431K (Europe)

06435 (Europe)

04100K (Europe)

May 29, 2019

AVERY DENNISON MARKETING SPECIFICATION

TOLERANCES IN. = ± .030 IN.
MM = ± 0.7 mm

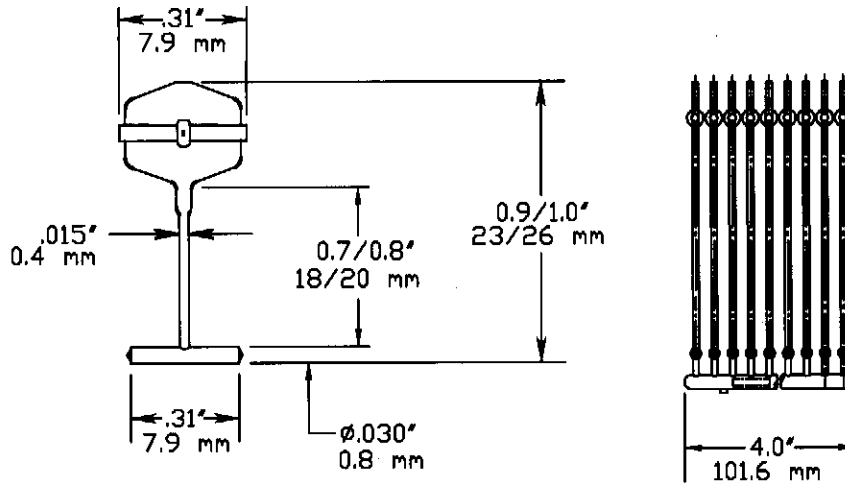

NOT TO SCALE

NOMINAL TENSILE STRENGTH:	3.5 - 4.5 LBSF / 1.6 - 2.0 KGF
MATERIAL:	NYLON 6 - NATURAL
CLIP QUANTITY:	50
APPLICATION TOOL:	10312 FINE FABRIC PISTOL-GRIP MARK II HAND TOOL 08946 FINE FABRIC SCISSOR-GRIP MARK II HAND TOOL (CONTACT LOCAL SALES PERSON FOR INFORMATION ON POWER EQUIPMENT)
PACKAGED:	5,000/CTN., 50,000/CASE
T/F CONN PADDLES:	YES



FASTENER DIVISION
FITCHBURG, MA 01420 U.S.A.
TEL. 1-800-225-5913
FAX. 1-800-848-2169

DESCRIPTION:

3/4" (19 mm) FF Paddle, Natural

APPROVAL:

Edo M... 1-12-08

STOCK NO.

08938

REV

H-

AVERY DENNISON MARKETING SPECIFICATION

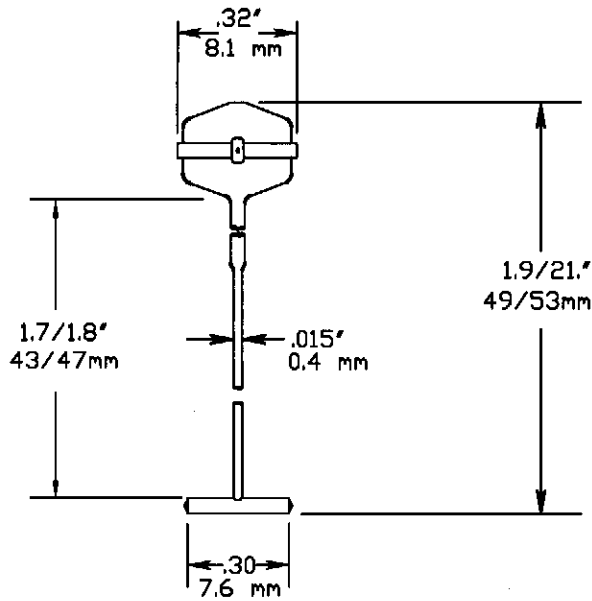

TOLERANCES: IN. = ± .030 in
MM = ±0.7 mm

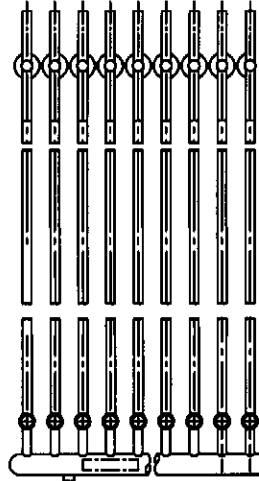

NOT TO SCALE

NOMINAL TENSILE STRENGTH:	3.5/4.5 LBSF / 1.5/2.0 KGF
MATERIAL:	POLYPROPYLENE - NATURAL
CLIP QUANTITY :	50
APPLICATION TOOL:	10312 FINE FABRIC PISTOL-GRIP MARK II HAND TOOL 08946 FINE FABRIC SCISSOR-GRIP MARK II HAND TOOL <CONTACT LOCAL SALES PERSON FOR INFORMATION ON POWERED EQUIPMENT>
PACKAGED:	5000/CTN., 50,000/CASE
T/F CONN PADDLES:	YES



FASTENER DIVISION
FITCHBURG, MA 01420 U.S.A.
TEL. 1-800-225-5913
FAX. 1-800-848-2169

DESCRIPTION:

2" (45mm) FF PADDLE

APPROVAL:

E. M. [Signature] 1-14-09

STOCK NO.

08939

REV

F

EVERY DENNISON MARKETING SPECIFICATION

TOLERANCES IN. =± .030 IN.
MM =± 0.7 mm

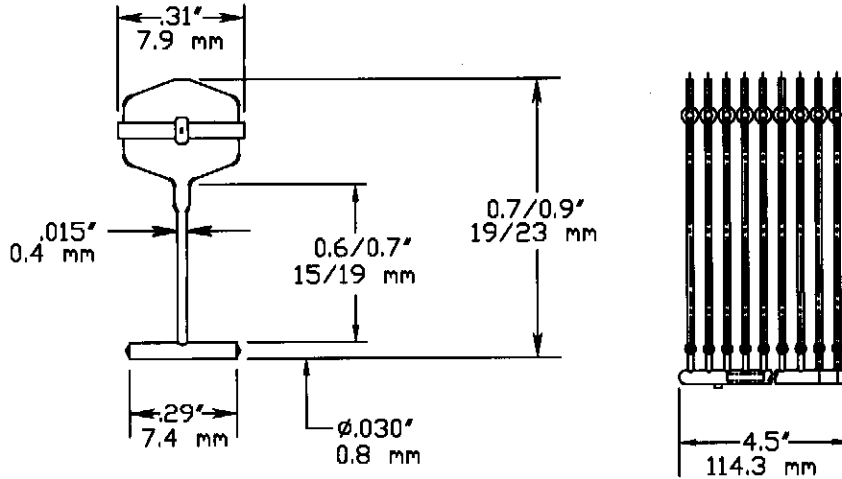

NOT TO SCALE

NOMINAL TENSILE STRENGTH:	3.5 - 4.5 LBSF / 1.5 - 2.0 KGF
MATERIAL:	POLYPROPYLENE - NATURAL
WEIGHT:	.022 GRAMS/EACH
CLIP QUANTITY:	100
APPLICATION TOOL:	10312 FINE FABRIC PISTOL-GRIP MARK II HAND TOOL (CONTACT LOCAL SALES PERSON FOR INFORMATION ON POWER EQUIPMENT)
PACKAGED:	10,000/CTN., 100,000/CASE
T/F CONN PADDLES:	YES



FASTENER DIVISION
FITCHBURG, MA 01420 U.S.A.
TEL. 1-800-225-5913
FAX. 1-800-848-2169

DESCRIPTION:

3/4" (17 mm) FF Paddle, Natural

APPROVAL:

[Signature] 1-12-09

STOCK NO.

10343

REV

E

VERY DENNISON MARKETING SPECIFICATION

TOLERANCES IN. =± .030 IN.
MM =± 0.7 mm

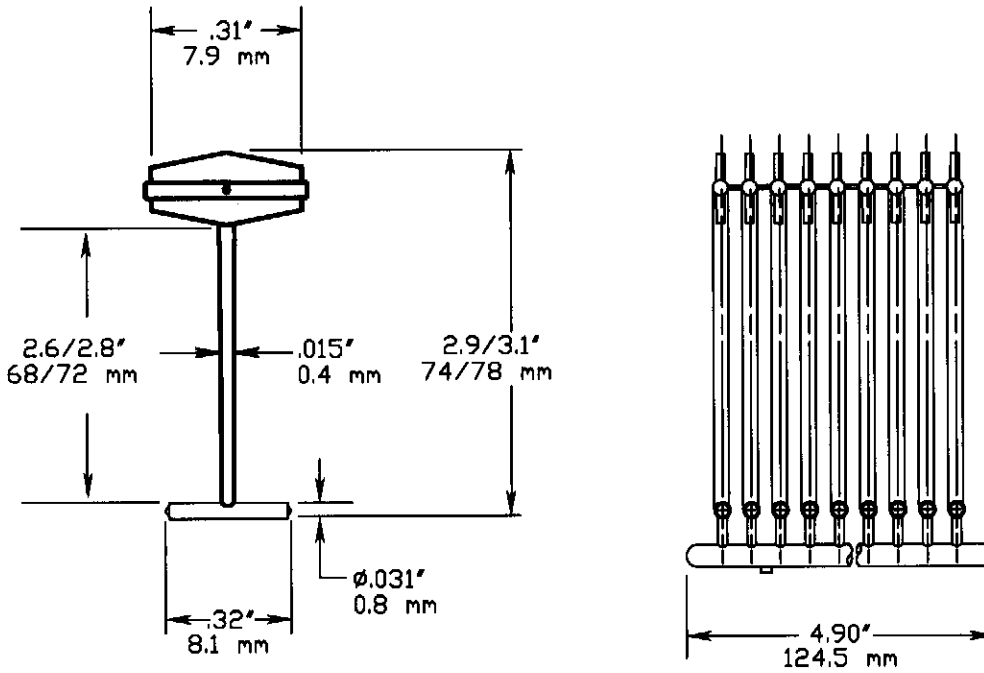

NOT TO SCALE

NOMINAL TENSILE STRENGTH:	3.5/4.5 LBSF / 1.5/2.0 KGF
MATERIAL:	POLYPROPYLENE - NATURAL
WEIGHT:	0.026 GRAMS/EACH
CLIP QUANTITY:	100
APPLICATION TOOL:	10312 MARK II FINE FABRIC PLUS TOOL SPU2M02 - INDUSTRIAL FF LONG NEEDLE SPU2M04 - INDUSTRIAL FF SHORT NEEDLE
PACKAGED IN:	10,000/CTN, 100,000/CASE
T/F CONN PADDLES:	YES



VERY DENNISON

FASTENER DIVISION
FITCHBURG, MA 01420 U.S.A.
TEL. 1-800-225-5913
MA. 978-353-8157

DESCRIPTION:

3" (70mm) SWIFTACH® FINE FABRIC PLUS

APPROVAL:

[Signature] 2-9-09

STOCK NO.

10347-1

REV

B

AVERY DENNISON MARKETING SPECIFICATION

TOLERANCES IN. = ± .030 IN.
MM = ± 0.7 mm

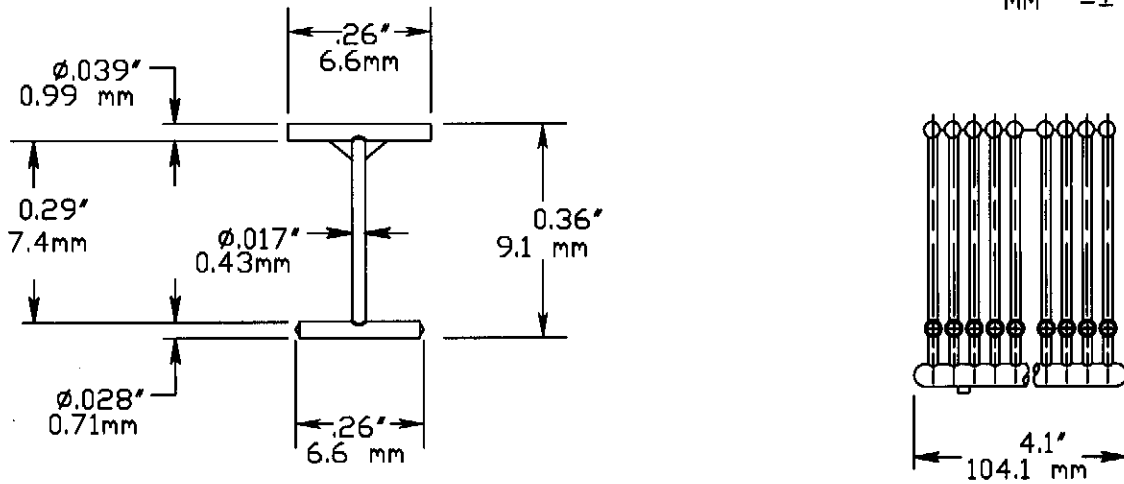

NOT TO SCALE

NOMINAL TENSILE STRENGTH:	3.5/4.5 LBSF. / 1.5/2.0 KGF.
MATERIAL:	NYLON 6 - NATURAL
WEIGHT/FASTENER:	0.012 grams/each
CLIP QUANTITY:	50
APPLICATION TOOL:	10312 FINE FABRIC PISTOL-GRIP MARK II HAND TOOL 08946 FINE FABRIC SCISSOR GRIP MARK II HAND TOOL (CONTACT LOCAL SALES PERSON FOR OTHER OPTIONS)
PACKAGED IN:	10,000/CTN, 100,000/CASE
TF CONNECTORS:	YES



FASTENER DIVISION
FITCHBURG, MA 01420 U.S.A.
TEL. 1-800-225-5913
FAX. 1-800-848-2169

DESCRIPTION:

1/4" (7mm) FINE FABRIC T-END PLUS
CONNECTED

APPROVAL:

Edley 1-30-09

STOCK NO.

10446-2

REV

F

AVERY DENNISON MARKETING SPECIFICATION

TOLERANCES IN. = ± .030 IN.
MM = ± 0.7 mm

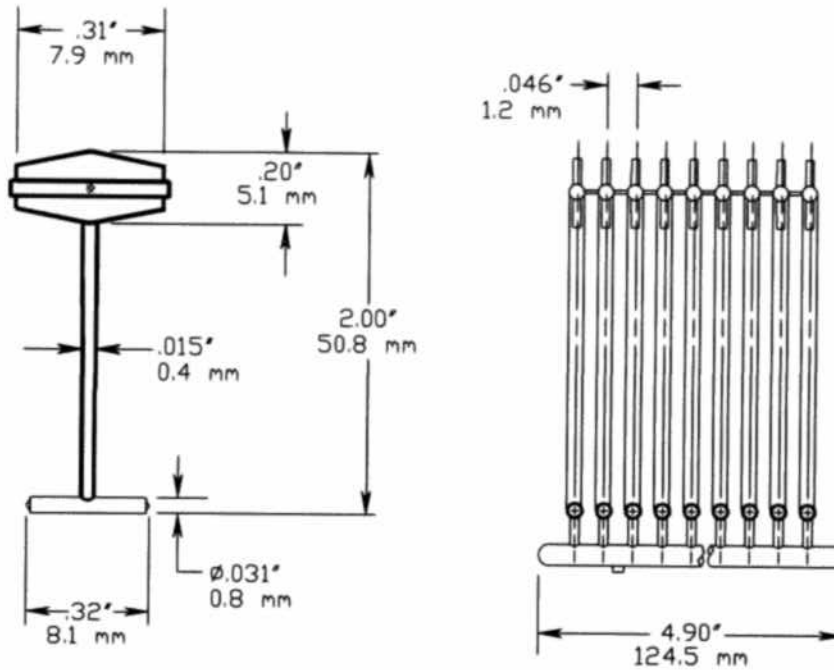

NOT TO SCALE

TENSILE STRENGTH:	4 LBSF.
MATERIAL:	POLYPROPYLENE
WEIGHT:	0.026 GRAMS/EACH
CLIP QUANTITY:	100
APPLICATION TOOL:	10312 MARK II FINE FABRIC PLUS TOOL SPU2M02 - INDUSTRIAL FF LONG NEEDLE SPU2M04 - INDUSTRIAL FF SHORT NEEDLE
PACKAGED IN:	10,000/CTN, 100,000/CASE
CONNECTED PADDLES:	YES



AVERY DENNISON

FASTENER DIVISION
FITCHBURG, MA 01420 U.S.A.
TEL. 1-800-225-5913
MA. 978-353-8157

DESCRIPTION:

2" SWIFTACH[®] FINE FABRIC PLUS

APPROVAL:

[Signature] 11-17-05

STOCK NO.

10670 NAT

REV

D

AVERY DENNISON MARKETING SPECIFICATION

TOLERANCES IN. =± .030 IN.
MM =± 0.7 mm

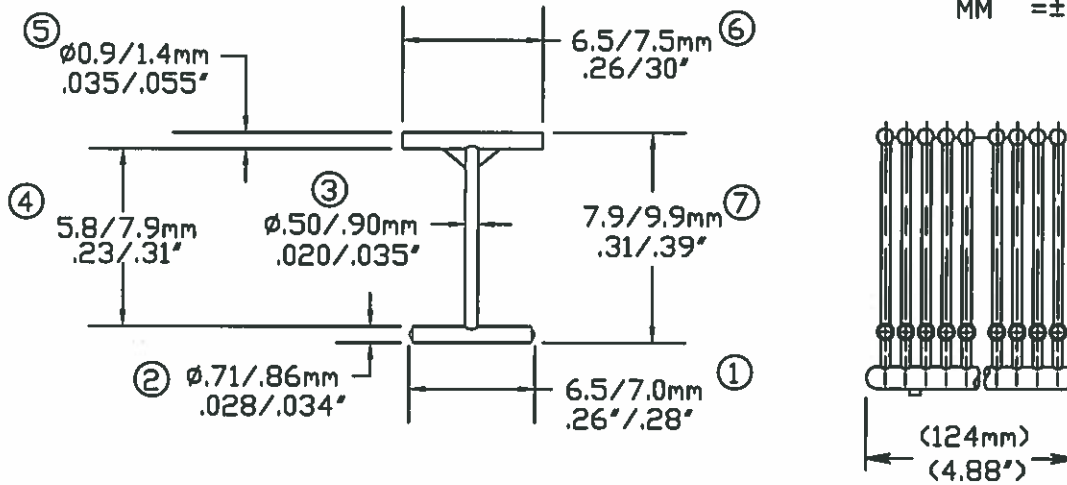

NOT TO SCALE

MIN. APPLIED TENSILE STRENGTH:	3.5 LBSF. / 1.6 KGF.
MATERIAL:	NYLON 6 - NATURAL
WEIGHT/FASTENER:	0.013 grams/each
CLIP QUANTITY:	100
APPLICATION TOOL:	10312 FINE FABRIC PISTOL-GRIP MARK II HAND TOOL <CONTACT LOCAL SALES PERSON FOR OTHER OPTIONS>
PACKAGED IN:	10,000/CTN, 100,000/CASE
TF CONNECTORS:	YES



FASTENER DIVISION
FITCHBURG, MA 01420 U.S.A.
TEL. 1-800-225-5913
FAX. 1-800-848-2169

DESCRIPTION:

1/4" (7mm) FINE FABRIC T-END PLUS

APPROVAL:

Linda Boyle 2/15/2016

STOCK NO.

10672-2

REV

J

AVERY DENNISON MARKETING SPECIFICATION

TOLERANCES:

INCHES: .XX ±.03
 INCHES: .XXX ±.010
 MM: .X ±.7
 MM: .XX ±.25

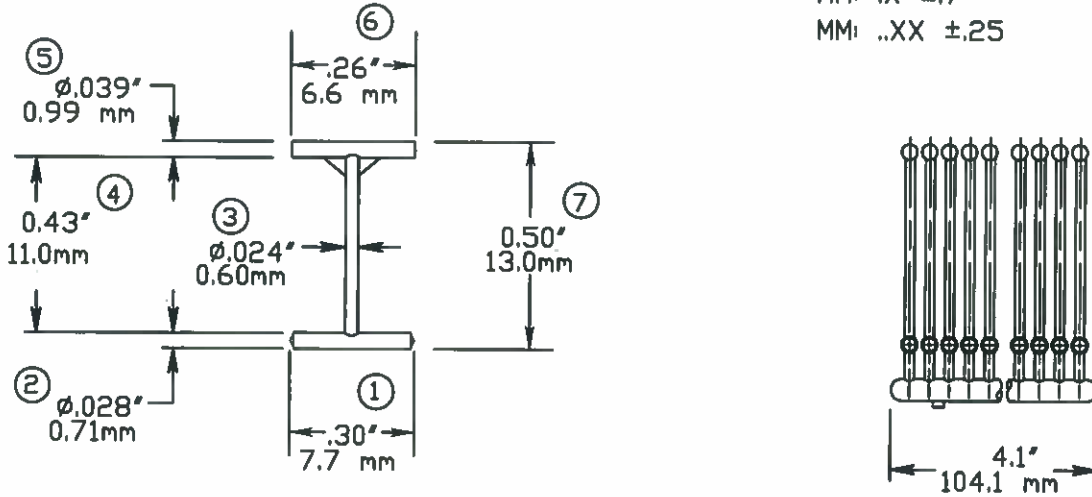

NOT TO SCALE

NOMINAL TENSILE STRENGTH:	3.5/4.5 LBSF. / 1.6/2.0 KGF.
MATERIAL:	NYLON 6 - NATURAL
WEIGHT/FASTENER:	0.028 grams/each
CLIP QUANTITY:	50
APPLICATION TOOL:	10312 FINE FABRIC PISTOL-GRIP MARK II HAND TOOL 08946 FINE FABRIC SCISSOR GRIP MARK II HAND TOOL (CONTACT LOCAL SALES PERSON FOR OTHER OPTIONS)
PACKAGED IN:	10,000/CTN, 100,000/CASE
TF CONNECTORS:	NO



FASTENER DIVISION
 FITCHBURG, MA 01420 U.S.A.
 TEL. 1-800-225-5913
 FAX. 1-800-848-2169

DESCRIPTION:

1/2" (11mm) FINE FABRIC T-END
 UN-CONNECTED

APPROVAL:

Linda Boyle 11-10-2016

STOCK NO.

10689-0

REV

L

EVERY DENNISON MARKETING SPECIFICATION

TOLERANCES IN. =± .030 IN.
MM =± 0.7 mm

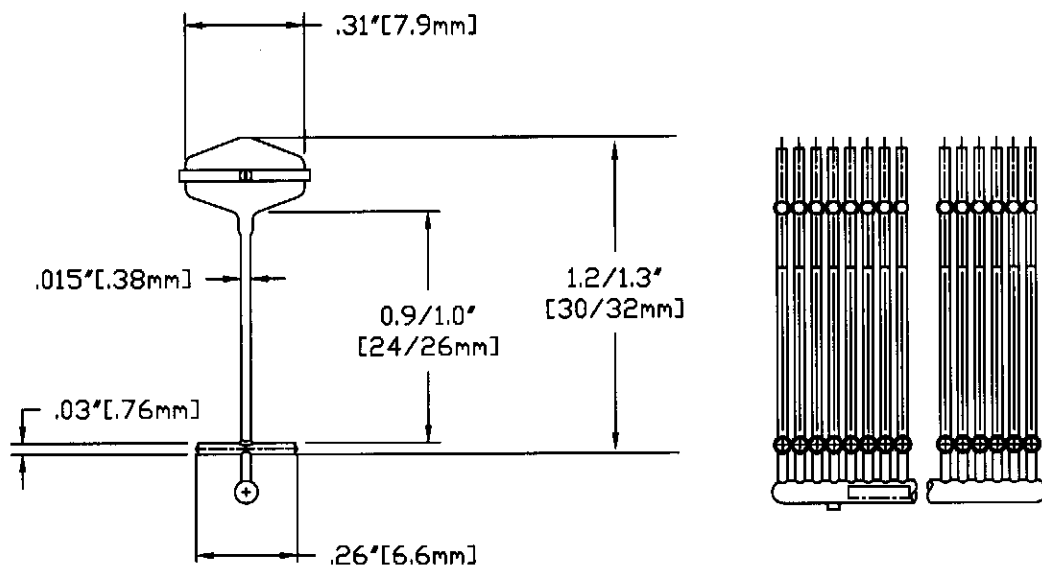

NOT TO SCALE

NOMINAL TENSILE STRENGTH:	3.5/4.5 LBSF. / 1.6/2.0 KGF.
MATERIAL:	POLYPROPYLENE
CLIP QUANTITY:	100
T/F CONN. PADDLES:	YES
PACKAGED:	10,000/CTN, 100,000/CASE
APPLICATION TOOL:	10312 FF PISTOL-GRIP MARK II HAND TOOL (CONTACT LOCAL SALES PERSON FOR INFORMATION ON POWERED EQUIPMENT)



FASTENER DIVISION
FITCHBURG, MA 01420 U.S.A.
TEL. 1-800-225-5913
MA. 978-353-8157

DESCRIPTION:

1"/25MM, FINE FABRIC PLUS
FILAMENT LENGTH

APPROVAL:

Edo H 2-3-09

STOCK NO.

10701

REV
D

AVERY DENNISON MARKETING SPECIFICATION

TOLERANCES IN. = ± .030 IN.
mm = ± 0.7mm

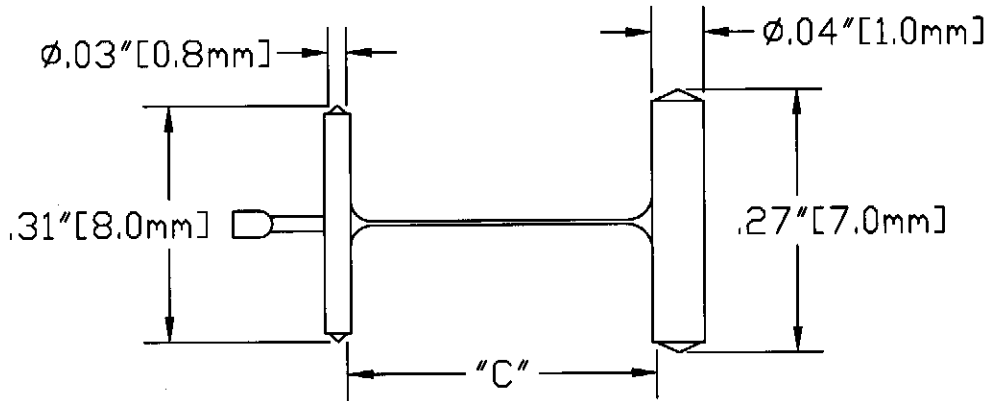

NOT TO SCALE

NOMINAL TENSILE STRENGTH:	4.5/5.5 LBSF. / 2.0/2.5 KGF.
MATERIAL:	NYLON - SEE TABLE
PIECES/CLIP:	100
PITCH:	CLOSE
PACKAGED:	10,000/CTN, 100,000/CASE
T/F CONN PADDLES:	YES

SKU #	REF. #	"C" DIM.	DESCRIPTION
11090	NATURAL	.18"/.22" [4.5/5.5mm]	13/64" [5mm]
11091	RED	"	"
11092	NATURAL	.25"/.29" [6.5/7.5mm]	9/32" [7mm]
11093	PINK	"	"
11094	NATURAL	.41"/.45" [10.5/11.5mm]	25/64" [10mm]
11095	BLACK	"	"



FASTENER DIVISION
FITCHBURG, MA 01420 U.S.A.
TEL. 1-800-225-5913
FAX. 1-800-848-2169

DESCRIPTION:

SWIFT, FINE FABRIC, T-END

APPROVAL:

[Signature] 6-30-09

STOCK NO.
SEE ABOVE

REV
D

AVERY DENNISON MARKETING SPECIFICATION

TOLERANCES IN. = ± .030 IN.
mm = ± 0.7mm

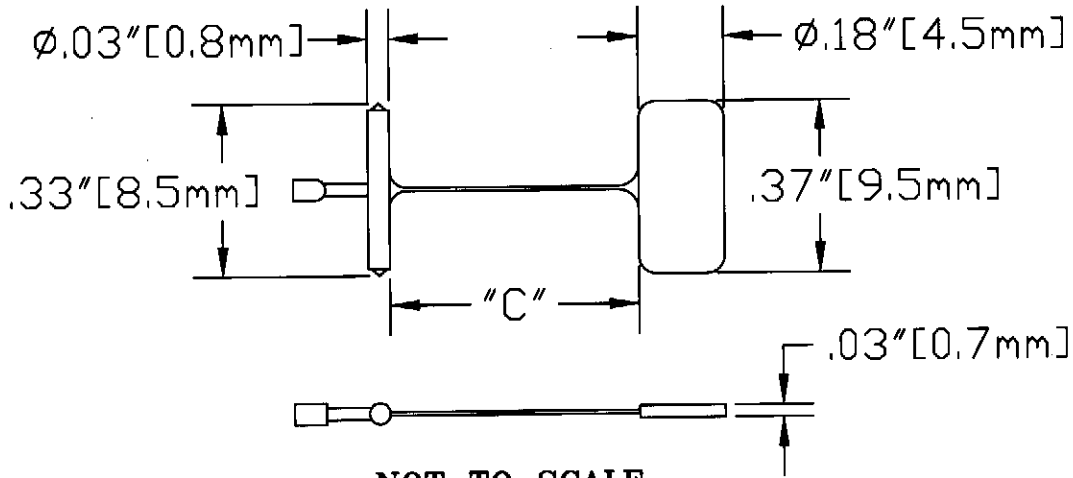

NOMINAL TENSILE STRENGTH:	4.5/5.5 LBSF. / 2.0/2.5 KGF.
MATERIAL:	NYLON - SEE TABLE
PIECES/CLIP:	SEE TABLE
PITCH:	CLOSE
PACKAGED:	10,000/CTN,100,000/CASE
T/F CONN PADDLES:	YES

SKU #	COLOR	"C" DIM.	DESCRIPTION	PCS./CLIP
11096	NATURAL	.57/.61"[14.5/15.5mm]	19/32" [15mm]	100
11097	RED	"	"	100
11098	BLUE	"	"	100
11099	BLACK	"	"	100
11100	BROWN	"	"	100
11106	NATURAL	"	"	100
11107	BLUE	"	"	100
11108	NATURAL	"	"	250
11109	BLUE	"	"	250
11101	NATURAL	.77/.80"[19.5/20.5mm]	25/32" [20mm]	100
11102	NATURAL	.96/1.0"[24.5/25.5mm]	1" [25mm]	100
11103	NATURAL	1.36/1.40"[34.5/35.5mm]	1 3/8" [35mm]	100
11104	NATURAL	1.95/2.0"[49.5/50.5mm]	2" [50mm]	100
11105	NATURAL	2.54/2.58"[64.5/65.5mm]	2 1/2" [65mm]	100



FASTENER DIVISION
FITCHBURG, MA 01420 U.S.A.
TEL. 1-800-225-5913
FAX. 1-800-848-2189

DESCRIPTION:

SWIFT, FINE FABRIC

APPROVAL:

[Signature] 1-30-09

STOCK NO.
SEE ABOVE

REV
D

AVERY DENNISON MARKETING SPECIFICATION

HISTORY

THE SUBJECT MATTER DISCLOSED HEREIN EMBODIES PROPRIETARY INFORMATION WHICH IS THE CONFIDENTIAL PROPERTY OF THE AVERY DENNISON CO. NONE OF WHICH SHALL BE COPIED, REPRODUCED, DISCLOSED TO OTHERS, PUBLISHED OR USED IN WHOLE OR IN PART, FOR ANY PURPOSE OTHER THAN THAT FOR WHICH IT IS BEING MADE AVAILABLE WITHOUT THE EXPRESS ADVANCE WRITTEN PERMISSION OF A DULY AUTHORIZED AGENT OF THE COMPANY. THIS DOCUMENT IS THE PROPERTY OF THE AVERY DENNISON CO. AND IS TO BE RETURNED TO THE COMPANY ON DEMAND.

REV.	DATE	DESCRIPTION
A	05.16.17	PRODUCTION RELEASE

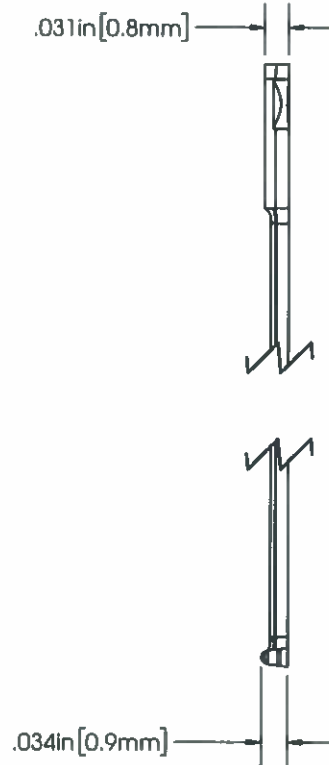
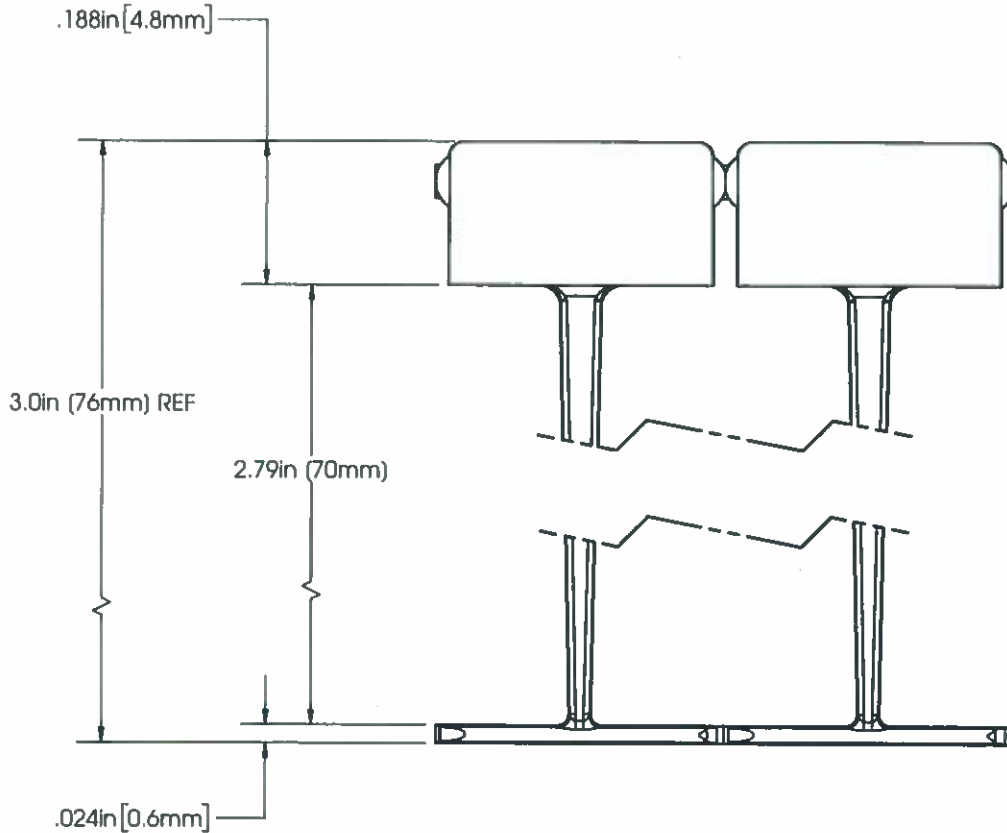

NOT TO SCALE

TENSILE STRENGTH:	2.2 lbf (998 g) MINIMUM	APPROVALS:	ENG. APPR. <i>[Signature]</i> 7-26-2017	AVERY DENNISON <small>FASTENER DIVISION FITCHBURG, MA 01420 U.S.A. TEL. 1-800-225-5913 FAX. 978-353-8157</small>	DESCRIPTION SYSTEM 500 FF, STD PADDLE, 3 IN
WEIGHT:	.04 GRAMS/EACH	Q.A. APPR. <i>[Signature]</i> 08/01/2017			
PACKAGED:	5000/CTN, 50,000/CASE	<u>SPECIFIED TOLERANCES ARE:</u>		MATERIAL POLYPROPYLENE	STOCK NO.
APPLICATION TOOL:	16010-0 - HAND TOOL <small>(CONTACT SALES SPECIALIST FOR ADDITIONAL OPTIONS)</small>	.XX ± .03 INCHES .X ± .7 mm .XXX ± .010 INCHES .XX ± .25 mm ANGULAR: ± 2°		COLOR NATURAL	16022-0
ROLL QUANTITY	500 FASTENERS				REV. A

5

4

3

2

1

AVERY DENNISON MARKETING SPECIFICATION

HISTORY

THE SUBJECT MATTER DISCLOSED HEREIN EMBODIES PROPRIETARY INFORMATION WHICH IS THE CONFIDENTIAL PROPERTY OF THE AVERY DENNISON CO. NONE OF WHICH SHALL BE COPIED, REPRODUCED, DISCLOSED TO OTHERS, PUBLISHED OR USED IN WHOLE OR IN PART FOR ANY PURPOSE OTHER THAN THAT FOR WHICH IT IS BEING MADE AVAILABLE WITHOUT THE EXPRESS ADVANCE WRITTEN PERMISSION OF A DULY AUTHORIZED AGENT OF THE COMPANY. THIS DOCUMENT IS THE PROPERTY OF THE AVERY DENNISON CO. AND IS TO BE RETURNED TO THE COMPANY ON DEMAND.

REV.	DATE	DESCRIPTION
A	05.16.17	PRODUCTION RELEASE

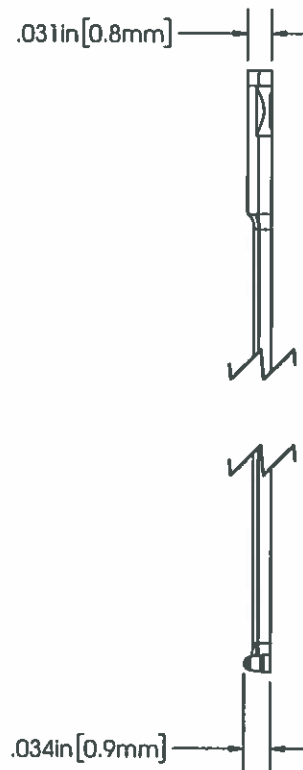
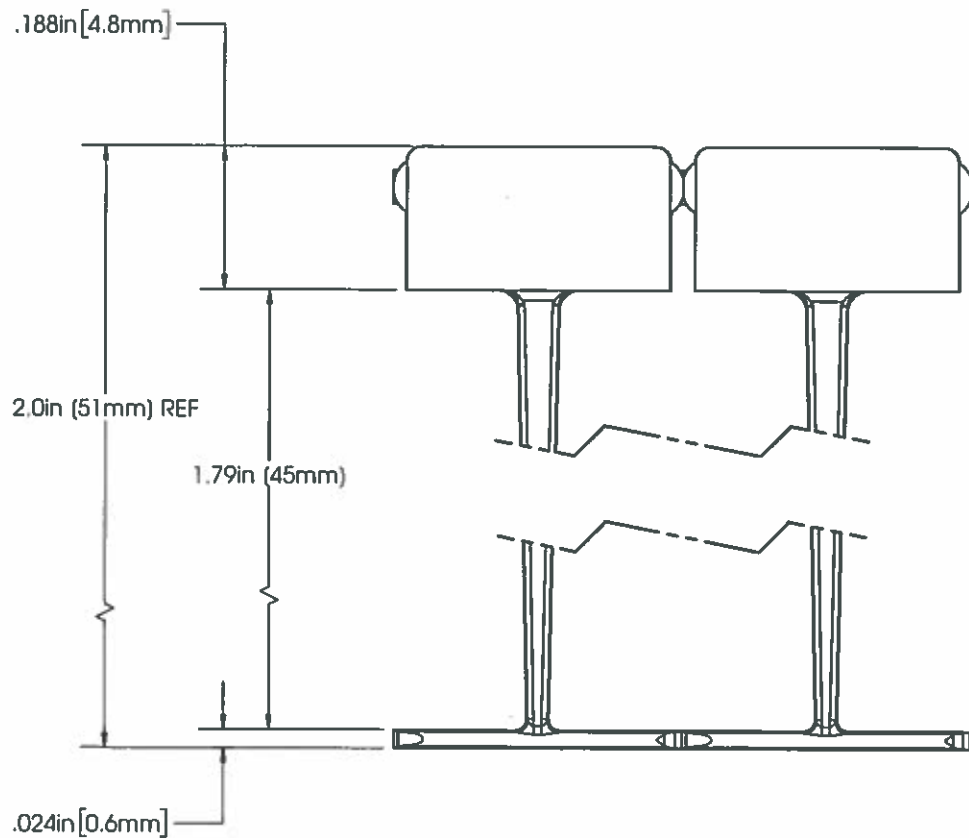

NOT TO SCALE

TENSILE STRENGTH:	2.2 lbf (998 g) MINIMUM	APPROVALS: ENG. APPR. <i>[Signature]</i> 7-26-2017 Q.A. APPR. <i>[Signature]</i> 08/01/2017	AVERY DENNISON		
WEIGHT:	.04 GRAMS/EACH			SPECIFIED TOLERANCES ARE: .XX ± .03 INCHES .X ± .7 mm .XXX ± .010 INCHES .XX ± .25 mm ANGULAR: ± 2°	MATERIAL POLYPROPYLENE
PACKAGED:	5000/CTN, 50,000/CASE		COLOR NATURAL	STOCK NO. 16023-0	REV. A
APPLICATION TOOL:	16010-0 - HAND TOOL <small>(CONTACT SALES SPECIALIST FOR ADDITIONAL OPTIONS)</small>				
ROLL QUANTITY:	500 FASTENERS				

5

4

3

2

1

AVERY DENNISON MARKETING SPECIFICATION

HISTORY

THE SUBJECT MATTER DISCLOSED HEREIN EMBODIES PROPRIETARY INFORMATION WHICH IS THE CONFIDENTIAL PROPERTY OF THE AVERY DENNISON CO. NONE OF WHICH SHALL BE COPIED, REPRODUCED, DISCLOSED TO OTHERS, PUBLISHED OR USED IN WHOLE OR IN PART, FOR ANY PURPOSE OTHER THAN THAT FOR WHICH IT IS BEING MADE AVAILABLE WITHOUT THE EXPRESS ADVANCE WRITTEN PERMISSION OF A DULY AUTHORIZED AGENT OF THE COMPANY. THIS DOCUMENT IS THE PROPERTY OF THE AVERY DENNISON CO. AND IS TO BE RETURNED TO THE COMPANY ON DEMAND.

REV.	DATE	DESCRIPTION
A	05.16.17	PRODUCTION RELEASE

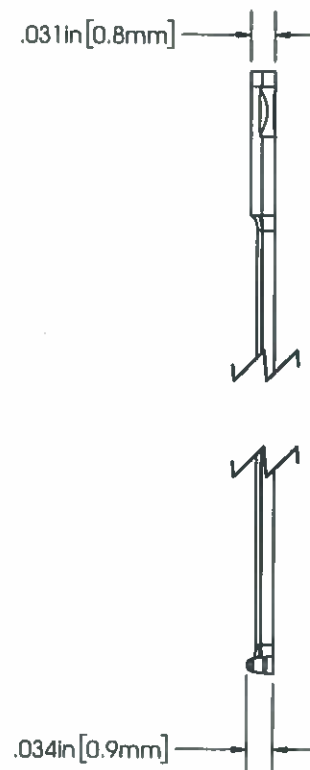
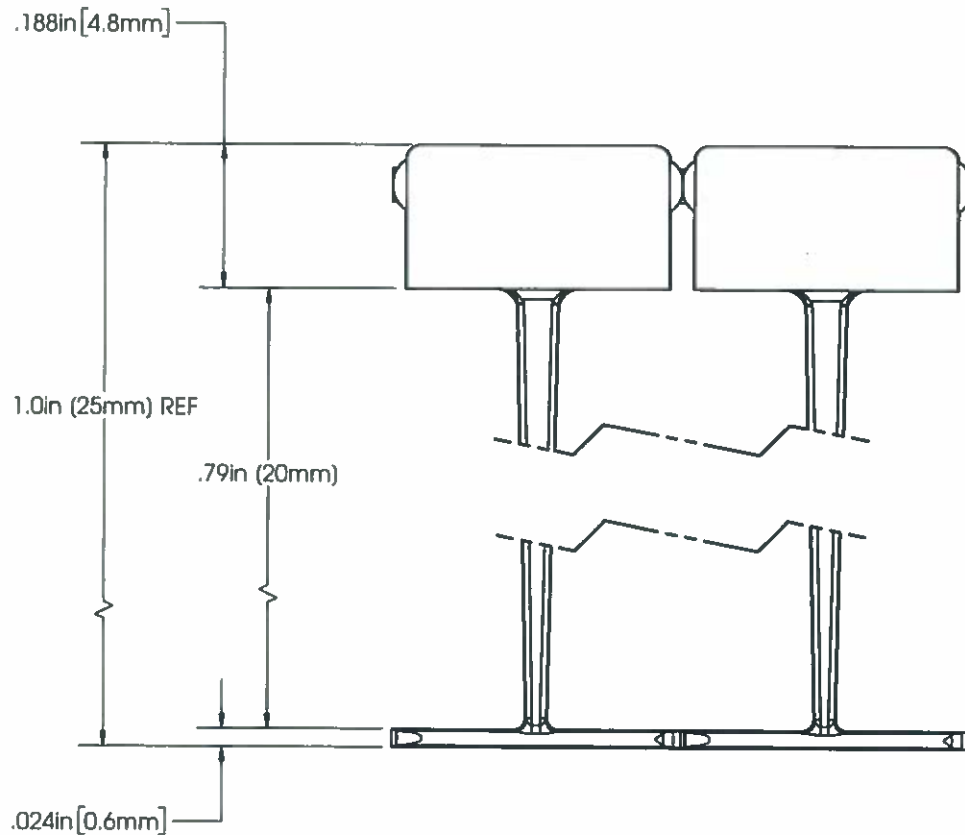

NOT TO SCALE

TENSILE STRENGTH:	2.2 lbf (998 g) MINIMUM	ENG. APPR. <i>[Signature]</i> 7-26-2017	AVERY DENNISON <small>FASTENER DIVISION FITCHBURG, MA 01420 U.S.A. TEL. 1-800-225-5913 FAX. 978-353-8157</small>	
WEIGHT:	.04 GRAMS/EACH	Q.A. APPR. <i>[Signature]</i> 05/10/2017		
PACKAGED:	5000/CTN. 50,000/CASE	<u>SPECIFIED TOLERANCES ARE:</u>		MATERIAL POLYPROPYLENE
APPLICATION TOOL:	16010-0 - HAND TOOL <small>(CONTACT SALES SPECIALIST FOR ADDITIONAL OPTIONS)</small>	.XX ± .03 INCHES .X ± .7 mm .XXX ± .010 INCHES .XX ± .25 mm ANGULAR: ± 2°		DESCRIPTION SYSTEM 500 FF, STD PADDLE, 1 IN
ROLL QUANTITY	500 FASTENERS			COLOR NATURAL
				STOCK NO. 16024-0
				REV. A

5

4

3

2

1

AVERY DENNISON MARKETING SPECIFICATION

HISTORY

THE SUBJECT MATTER DISCLOSED HEREIN EMBODIES PROPRIETARY INFORMATION WHICH IS THE CONFIDENTIAL PROPERTY OF THE AVERY DENNISON CO. NONE OF WHICH SHALL BE COPIED, REPRODUCED, DISCLOSED TO OTHERS, PUBLISHED OR USED IN WHOLE OR IN PART, FOR ANY PURPOSE OTHER THAN THAT FOR WHICH IT IS BEING MADE AVAILABLE WITHOUT THE EXPRESS ADVANCE WRITTEN PERMISSION OF A DULY AUTHORIZED AGENT OF THE COMPANY. THIS DOCUMENT IS THE PROPERTY OF THE AVERY DENNISON CO. AND IS TO BE RETURNED TO THE COMPANY ON DEMAND.

REV.	DATE	DESCRIPTION
A	05.16.17	PRODUCTION RELEASE

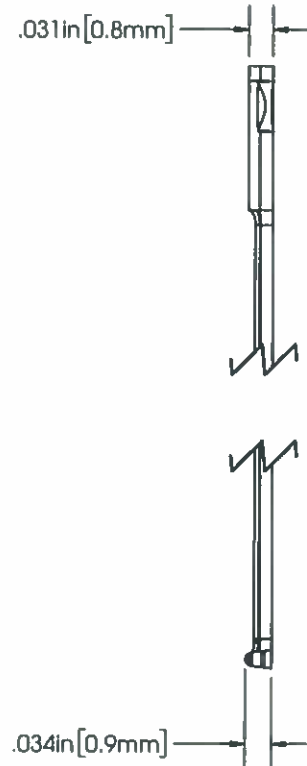
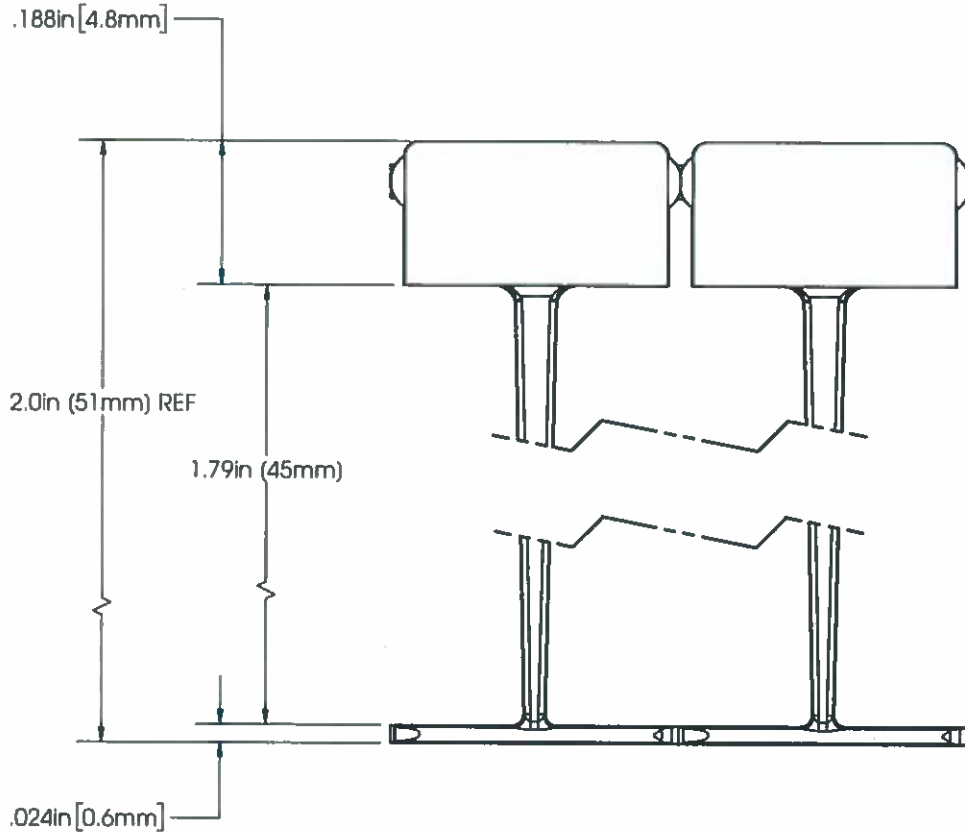

NOT TO SCALE

TENSILE STRENGTH:	4.0 lbf (1814 g) MINIMUM	APPROVALS: ENG. APPR. <i>[Signature]</i> 7-26-2017 Q.A. APPR. <i>[Signature]</i> 05/29/2017	 AVERY DENNISON FASTENER DIVISION FITCHBURG, MA 01420 U.S.A. TEL. 1-800-225-5913 FAX. 978-353-8157	DESCRIPTION SYSTEM 500 FF, STD PADDLE, 2 IN
WEIGHT:	.05 GRAMS/EACH			
PACKAGED:	5000/CTN, 50,000/CASE			
APPLICATION TOOL:	16010-0 - HAND TOOL (CONTACT SALES SPECIALIST FOR ADDITIONAL OPTIONS)	SPECIFIED TOLERANCES ARE: .XX ± .03 INCHES .X ± .7 mm .XXX ± .010 INCHES .XX ± .25 mm ANGULAR: ± 2°	MATERIAL NYLON 6	STOCK NO. 16025-0
ROLL QUANTITY	500 FASTENERS		COLOR NATURAL	REV. A

5

4

3

2

1

AVERY DENNISON MARKETING SPECIFICATION

HISTORY

THE SUBJECT MATTER DISCLOSED HEREIN EMBODIES PROPRIETARY INFORMATION WHICH IS THE CONFIDENTIAL PROPERTY OF THE AVERY DENNISON CO. NONE OF WHICH SHALL BE COPIED, REPRODUCED, DISCLOSED TO OTHERS, PUBLISHED OR USED IN WHOLE OR IN PART, FOR ANY PURPOSE OTHER THAN THAT FOR WHICH IT IS BEING MADE AVAILABLE WITHOUT THE EXPRESS ADVANCE WRITTEN PERMISSION OF A DULY AUTHORIZED AGENT OF THE COMPANY. THIS DOCUMENT IS THE PROPERTY OF THE AVERY DENNISON CO. AND IS TO BE RETURNED TO THE COMPANY ON DEMAND.

REV.	DATE	DESCRIPTION
A	05.16.17	PRODUCTION RELEASE

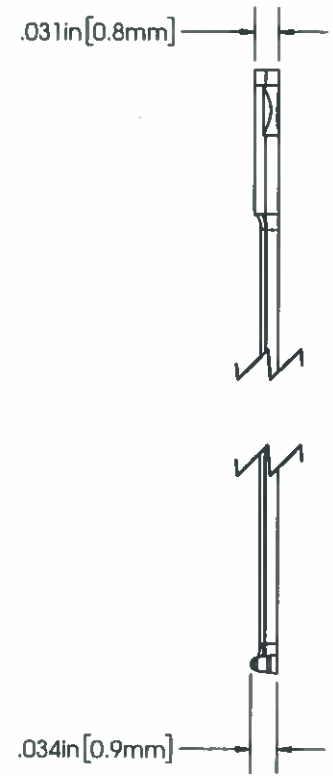
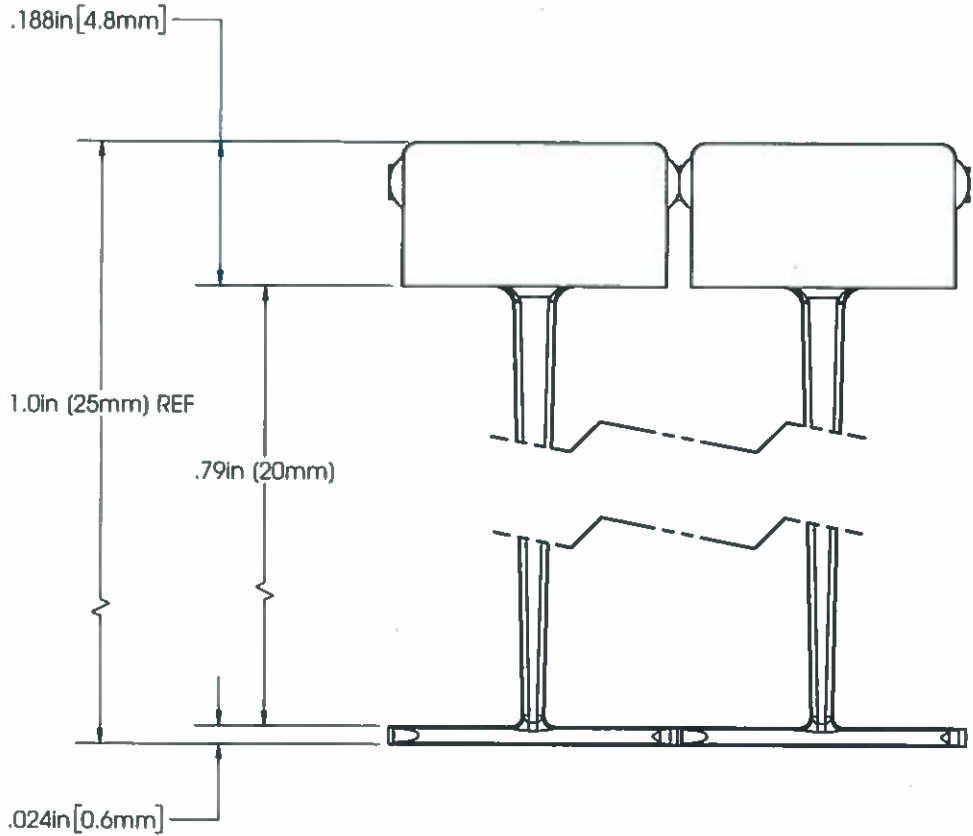

NOT TO SCALE

TENSILE STRENGTH:	4.0 lbf (1814 g) MINIMUM	APPROVALS:	ENG. APPR. <i>[Signature]</i> 7-26-2017	AVERY DENNISON <small>FASTENER DIVISION FITCHBURG, MA 01420 U.S.A. TEL: 1-800-225-5913 FAX: 978-353-8157</small>
WEIGHT:	.05 GRAMS/EACH	Q.A. APPR. <i>[Signature]</i> 08/01/2017		
PACKAGED:	5000/CTN, 50,000/CASE	SPECIFIED TOLERANCES ARE:		DESCRIPTION SYSTEM 500 FF, STD PADDLE, 1 IN
APPLICATION TOOL:	16010-0 - HAND TOOL <small>(CONTACT SALES SPECIALIST FOR ADDITIONAL OPTIONS)</small>	.XX ± .03 INCHES .X ± .7 mm	MATERIAL NYLON 6	
ROLL QUANTITY	500 FASTENERS	.XXX ± .010 INCHES .XX ± .25 mm	COLOR NATURAL	STOCK NO. 16026-0
		ANGULAR: ± 2°		REV. A

AVERY DENNISON PRODUCT SPECIFICATION

艾利丹尼森公司产品规格说明书

UNIT 单位: MM

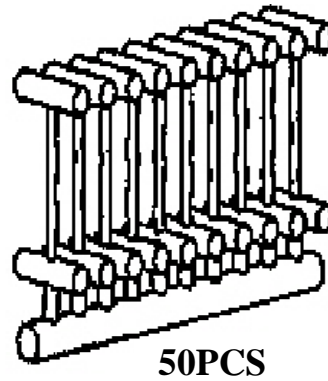
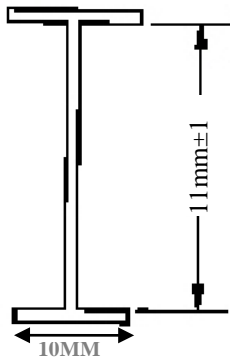

NOT TO SCALE

注意: 以上图示不成比例, 使用时请注意实际数值

TENSILE STRENGTH	拉伸强度	≥3.5 LBS	≥3.5 磅
MATERIAL	原材料	NY6-F223D	尼龙 6
CONCENTRATE	色料	无	
WEIGHT PER PCS	每支称重	0.017 GRAMS/EACH	0.017 克/支
APPLICATION TOOLS	使用工具	FF III™PISTOL TOOL STOCK # 库存编号	特幼 III™胶针枪
PCS PER CLIP	每排胶针数量	50 PCS	50 支/排
PCS PER INNER BOX	内装数	10, 000 PCS	10,000 支/盒
PCS PER OUTER CARTON	外装数	100,000 PCS	100,000 支/箱
CONNECTED PADDLE	平浆连线	YES	有

Description 产品名称 SW 11 FF TEND NAT NY AD 11MM FFP 尼龙胶针	Doc No. 06435/10689-0	Rev. 01	Prepared by Jian	Date Feb 16 th 2011
Part No 产品编号 06435/10689-0	Issuing Dept. ENG	Page No. 1 / 1	Approved by	Date